

SC-1 System Controller

OWNER'S MANUAL

Contents

Introduction	3
Warranty	4
Precautions	5
1. Top panel	6
1.1 Primary functions of switches.	
1.2 Secondary functions of switches.	
2. Rear panel	9
3. Midi devices	10
4. Operating the SC-1	11
5. SC-1 menu schematic	12
6. Getting started	13
7. Operation modes	14
8. Preset mode	15
9. Song mode	16
9.1 Accessing the song mode	
9.2 Modifying a song	
10. Set mode	18
10.1 Accessing the set mode	
10.2 Editing the set	
11. Midi menu	20
11.1 Program Change menu	
11.2 Controllers menu	
11.3 Pedals menu	
12. Titles menu	25
13. Copy menu	26
13.1 Copy a bank-preset	
13.2 Copy a song	
14. System menu	27
14.1 Midi Bulk	
14.2 Version	
14.3 Restore	
14.4 Pedals	
15. Cables	30
16. Midi appendix	31

Introduction

Congratulations on your purchase of the SRD SC-1 System Controller.

The SC-1 System Controller was designed to provide ultimate flexibility in MIDI controlling, combined with a rugged design for years of trouble free and reliable use.

This manual will introduce you to the SC-1 System Controller and its features. After reading this manual carefully please keep it for future reference.

We are confident that you very quickly will be familiar with the SC-1 System Controller, and appreciate the versatility and high quality of this unit.

Steen Skrydstrup.
President.

SKRYDSTRUP RESEARCH & DEVELOPMENT
MOEGELMOSEVEJ 54
DK-6630 ROEDDING
DENMARK.

Tel.: +45 7536 6174
Fax: +45 7536 6179
Web: www.skrydstrup.com

Warranty

- All parts and workmanship of this SKRYDSTRUP R&D product are fully guaranteed to be free of defects under normal use and service for a period of TWO years from date of purchase.
- This warranty will remain in effect until the original expiration date.
- Any damage resulting from mis-use or failure to follow instructions and precautions as stated in this manual, will void this warranty.
- Should this product require repair, SKRYDSTRUP R&D will assume responsibility for repair service. Re-pack the unit, along with a description of the problem, and send it to SKRYDSTRUP R&D.
- Removing or altering the original serial number, will void this warranty.
- Altering this product in general, will void this warranty.
- SKRYDSTRUP R&D reserves the right to make changes in design and/or improvements upon this product, without any obligation to include those changes in any products previously manufactured.

Precautions

NOTE: IT IS VERY IMPORTANT THAT YOU READ THIS SECTION CAREFULLY TO PROVIDE YEARS OF TROUBLE FREE USE. THIS UNIT REQUIRES CAREFUL USE.

DO NOT...

- ATTEMPT TO SERVICE THIS EQUIPMENT. QUALIFIED PERSONNEL SHOULD SERVICE THIS EQUIPMENT ONLY.
- REMOVE THE COVER FROM THIS EQUIPMENT AT ANY TIME.
- MAKE INTERNAL ADJUSTMENTS OR ADDITIONS TO THIS EQUIPMENT AT ANY TIME.
- TAMPER WITH INTERNAL ELECTRONIC COMPONENTS AT ANY TIME. FAILURE TO FOLLOW THESE INSTRUCTIONS MAY VOID WARRANTY SERVICE TO THIS EQUIPMENT, AS WELL AS SHOCK HAZARD.
- EXPOSE THIS UNIT TO EXCESSIVE HEAT. THIS UNIT IS DESIGNED TO OPERATE BETWEEN 0° C AND 40° C.
- USE THIS EQUIPMENT NEAR WATER. CARE SHOULD BE TAKEN SO THAT OBJECTS DO NOT FALL AND LIQUIDS ARE NOT SPILLED INTO THE UNIT THROUGH ANY OPENINGS.
- USE SOLVENTS SUCH AS BENZINE, ETC. TO CLEAN THE EXTERIOR. USE A DRY SOFT CLOTH TO REMOVE DUST, DIRT OR FINGERMARKS.

SKRYDSTRUP R&D

SC-1 System Controller

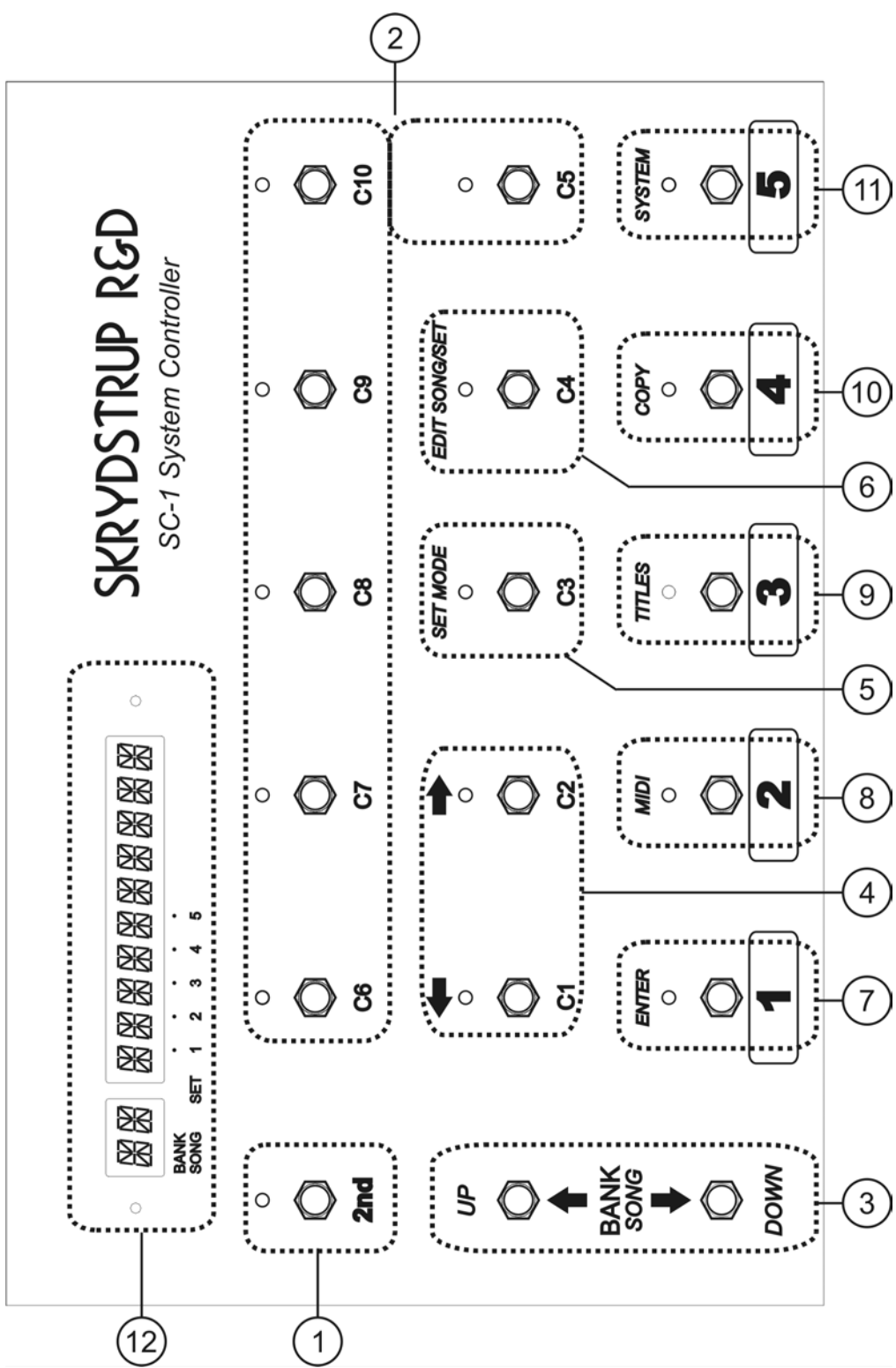

1. Top Panel

The numbers inside the circles refers to the numbers on the drawing page 6.

2ND ① switch:

This switch selects between the primary and the secondary function of every switch on the SC-1.

The primary function of all switches corresponds to the label below the switch, while the secondary function corresponds to the label above the switch. When this switch is pressed the LED turns on, indicating the secondary functions are available. When the switch is pressed again, the LED turns off, indicating the primary functions are available.

1.1 Primary function of the switches:

C1 - C2④, C3⑤, C4⑥, C5 - C10② switches:

The primary functions of these switches are to initiate the corresponding MIDI controller change transmissions, if programmed.

1 switch: ⑦

Recalls preset number 1.

2 switch: ⑧

Recalls preset number 2.

3 switch: ⑨

Recalls preset number 3.

4 switch: ⑩

Recalls preset number 4.

5 switch: ⑪

Recalls preset number 5.

UP ARROW “↑” and DOWN ARROW “↓” (BANK/SONG) ③ switches:

The function of these switches are to decrement and increment the bank number and song number.

If pressed and held down, the bank or song number will be scrolled, until either of the switches is released.

1.2 Secondary function of the switches:

LEFT “←” ARROW and C2/ RIGHT “→” ARROW ④ switches:

The secondary function for these switches is to move the cursor in the 12-character display between the sections available and to step forward and backwards in the various menus.

SET MODE ⑤ switch:

Enters the SET MODE menu.

EDIT SONG/SET ⑥ switch:

Enters the EDIT SONG/SET menu.

ENTER ⑦ switch:

Used for selecting menus, storing changes, executing functions, etc.

MIDI ⑧ switch:

Enters the MIDI menu.

TITLES ⑨ switch:

Enters the TITLES edit function.

COPY ⑩ switch:

Enters the COPY function.

SYSTEM ⑪ switch:

Enters the SYSTEM menu.

UP ARROW “↑” and DOWN ARROW “↓” (BANK/SONG) ⑬ switches:

The function of these switches are to decrement and increment the bank number and song number.

If pressed and held down, the bank or song number will be repetitive accelerating decremented or incremented, until either of the switches is released.

DISPLAY ⑫

The display consists of 12 alphanumeric characters of 14 segments each.

It is used to display user-programmed preset or song titles, as well as programmed MIDI data, system status and system messages.

The decimal points are used to indicate if set mode is active and which set number is active.

2. Rear Panel

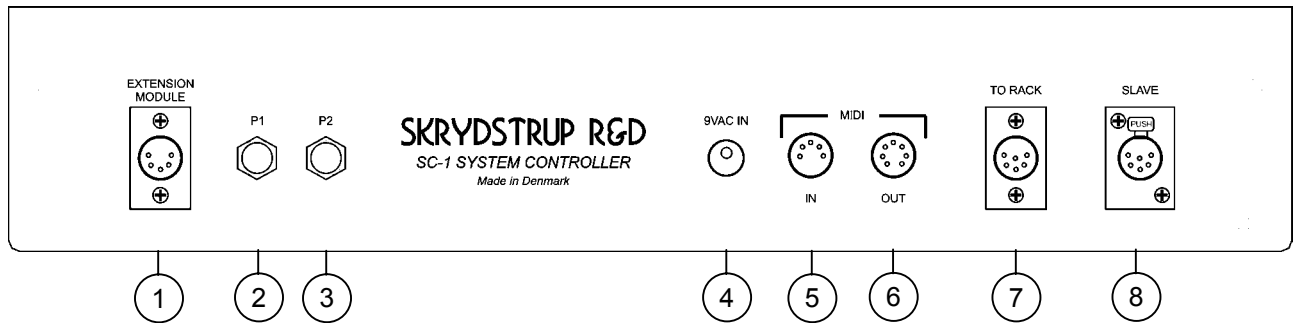

- 1) **EXTENSION MODULE XLR Connector:** This 5-pin XLR connector takes a cord to provide power as well as information lines between SC-1 and the Extension Module.
- 2) **P1 JACK:** standard 1/4" stereo.
This jack provides connection for an external expression pedal.
Tip=pedal input Ring=pedal output Sleeve=ground
The ring of this jack is internally wired to +5V through a 200 Ohm resistor, so that external short circuits will not damage the unit. Maximum resistance of the expression pedal is not critical (see section 15 for further information).
- 3) **P2 JACK:** same specifications as P1 jack.
- 4) **9VAC IN:** 2.1mm DC bushing for supplying the SC-1 with 9VAC.
The SC1 will require a min. of 300mA, and 375mA with the Extension.
- 5) **MIDI IN:** 5-pin DIN connector providing the SC-1 with incoming MIDI data. This connector is used for MIDI Bulk Load and firmware-update functions.
- 6) **MIDI OUT:** 7-pin DIN connector. This 7-pin connector takes a 7-pin MIDI cable to provide power for the SC-1, as well as sending MIDI data to external MIDI devices. This connector can be used together with MIDI IN on SKRYDSTRUP R&D MR-8 Loop System.
A common 5-pin MIDI cable can also be used, if the 9VAC in is used for powering.
- 7) **TO RACK XLR Connector:** This 6-pin XLR connector takes a cord to provide power as well as MIDI IN/OUT information lines between the SC-1 and a SKRYDSTRUP R&D System Interface.
The PIN configuration is:
PIN 1 : 9VAC
PIN 2 : MIDI IN +
PIN 3 : MIDI OUT +
PIN 4 : MIDI OUT -
PIN 5 : MIDI IN -
PIN 6 : 9VAC
- 8) **SLAVE XLR Connector:** This 6-pin XLR connector takes a cord to provide power as well as information lines between additional SC-1's. Contact factory for details.

3. Midi devices

External MIDI devices can be connected to the SC-1 MIDI Out. The MIDI Thru of the first MIDI device passes on the original MIDI signal sent to MIDI In. There is a limit to how many MIDI devices you can connect like this – in series.

A distortion and delay of the MIDI signal can occur, causing errors in the MIDI signal. To solve this problem a MIDI Thru Box can be used. A MIDI Thru Box will supply multiple buffered MIDI Outs. Keep MIDI cables as short as possible, not exceeding 15 meters in length.

SC-1 rear

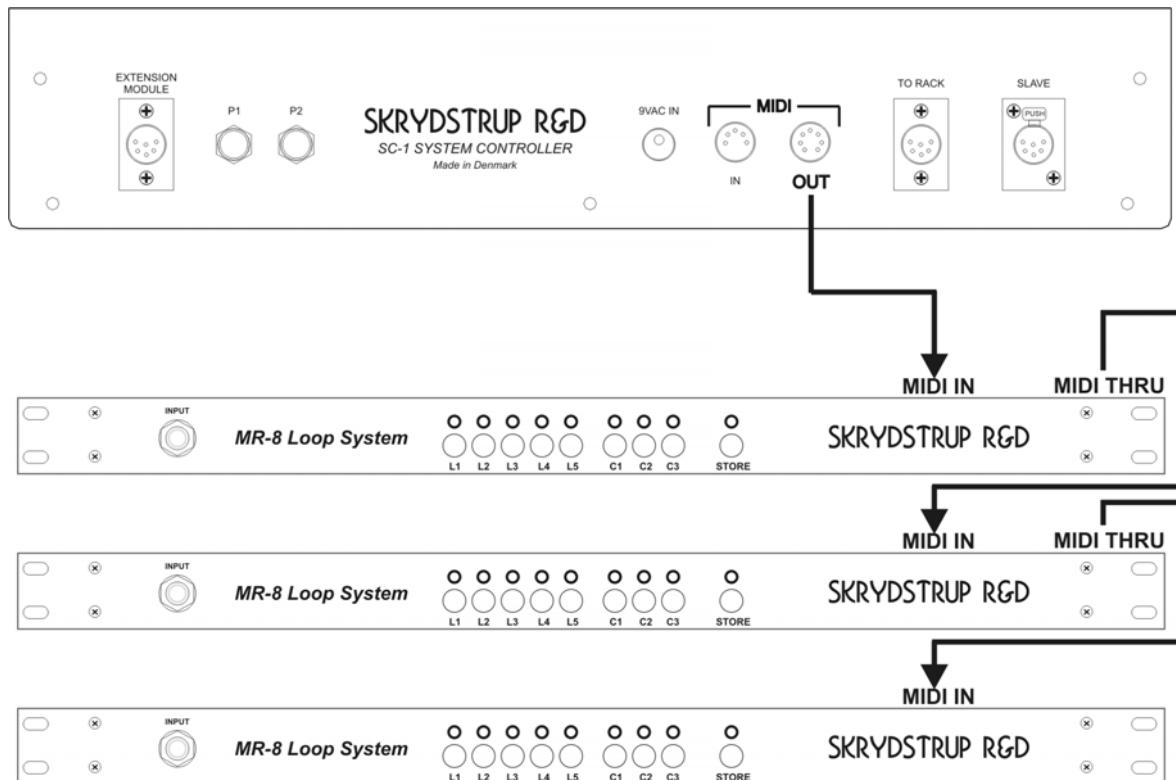

4. Operating the SC-1

To get quickly started using the SC-1 there is some basic concepts regarding the user interface that is worth knowing for better and faster operation of the machine.

4.1 Primary operation

When operating in primary mode the preset switches 1-5 are used for selecting presets, the controller switches C1-C10 are used for control change operations, the up “↑” and down “↓” arrows selects the bank or song number which is shown in the BANK/SONG part of the display. The title of the preset/song is shown in the larger 10-character part of the display.

The preset switches selects one of the five presets available in each bank/song. When pressing one of these switches the selected preset will be instantly recalled and all pre programmed MIDI data will be sent.

The controller switches C1-C10 are used for sending MIDI control change messages. When recalling a preset the states of the controllers are used for sending either on (7Fh) or off (00h) control changes to i.e. a loop system or an effects processor. These controllers can also be toggled while using the preset by pressing the desired controller. A controller can be turned off – so don't be alarmed if a controller does not respond. Storing the change is done by pressing 2nd followed by ENTER (only in preset mode). When repressing the selected preset switch, the preset is restored to its last stored state.

The up “↑” and down “↓” arrows lets you select the current bank or song number. When pressing either of these switches the BANK/SONG display will start blinking, indicating that the shown bank/song number is not the current. Pressing a preset number will recall the selected preset number in the selected bank.

When operating in set mode the dot-points in the bottom of the display indicates the current set number.

4.2 Secondary operation

Pressing the 2nd switch accesses the secondary mode. The 2nd LED will be lit indicating that secondary functions are available. These functions are listed above the switches. By pressing any of the titled switches you will access the features of the selected function.

Many of these functions use menus where you can scroll between the menu items by pressing the up “↑” and down “↓” arrows. Press the right arrow “→” or ENTER to select the desired menu item. Press the left arrow “←” to step back to the previous menu or press the function switch the go back to the root of the menu.

A blinking dot-point appears when entering a page where parameters can be edited. This dot-point is your cursor and can be moved between the parameters with the left and right arrows. The parameter can be altered with the up “↑” and down “↓” arrows when the cursor is positioned next to it. Stepping back to the previous menu is done by moving the cursor to the first parameter and pressing the left “←” arrow.

Please note: Not all of the secondary functions are available in some operating modes.

See the detailed descriptions of the secondary functions (referred to as “menus”) further on in this manual.

5. SC-1 menu schematic

Below is shown a rough schematic layout of the three most important menus in the SC-1.

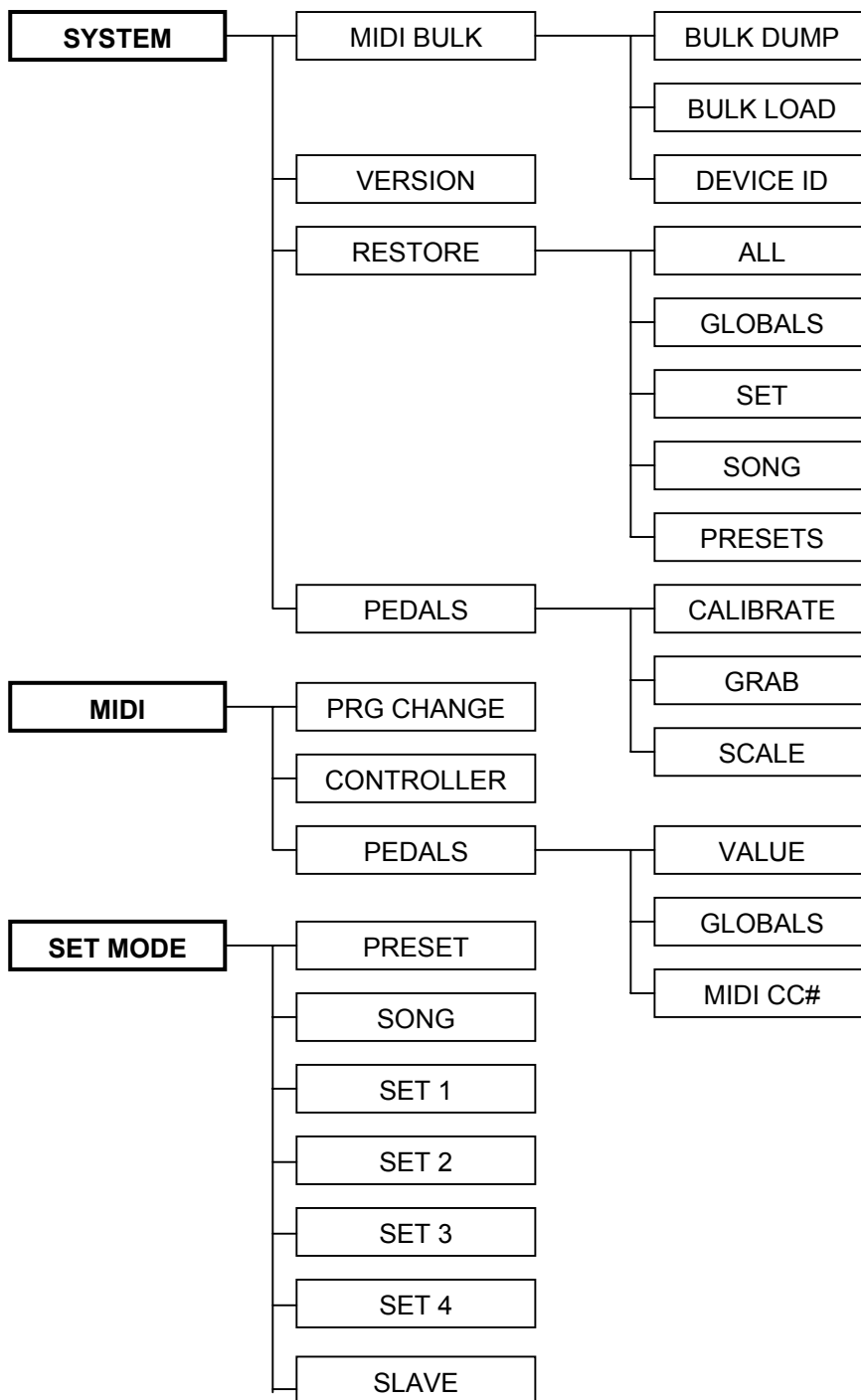

6. Getting started

1. Connect a Midi cable from SC-1 Midi Out to your system (See section 3)
2. Connect the 9VAC power supply to SC-1.

SC-1 is now functional.

To start using the SC-1 with your system, follow step 3 thru 11.

3. Select how you want the SC-1 to operate (See section 7)
4. Set up your controllers (See section 11)
5. Set up the scale of your external pedals used in P1/P2 (See section 14)
6. Calibrate your pedals (See section 14)
7. Set up the controller number and channel for each pedal used (See section 11)
8. If PDL VAL is selected ON, set up the actual pedal value (See section 11)
9. Set up any Midi Program Change messages you want to send (See section 11)
10. Rename your presets with a unique title (See section 12)

Step 8, 9 and 10 is repeated in every preset used.
You are now ready to perform with the SC-1.

7. Operating modes

The SC-1 can operate in several different modes. You can select any of these modes depending on your performance situation.

Modes available:

- **PRESETS** *Factory default.*
In PRESET mode the SC-1 is performing like a standard MIDI Foot Controller. 125 presets divided into 25 banks containing 5 presets each.
- **SONGS**
In SONG mode the particular information stored in each of the 125 presets can be arranged in any desired order, for access and recall during the performance of songs. Up to 99 songs can be created.
- **SET 1**
In SET mode you can group and arrange the 99 songs in any desired order within set 1. Set 1 can contain up to 50 songs.
- **SET 2**
In SET mode you can group and arrange the 99 songs in any desired order within set 2. Set 2 can contain up to 50 songs.
- **SET 3**
In SET mode you can group and arrange the 99 songs in any desired order within set 3. Set 3 can contain up to 50 songs.
- **SET 4**
In SET mode you can group and arrange the 99 songs in any desired order within set 4. Set 4 can contain up to 50 songs.
- **SET 5**
In SET mode you can group and arrange the 99 songs in any desired order within set 5. Set 5 can contain up to 50 songs.
- **SLAVE**
SLAVE mode is for use of multiple footswitch systems. One footswitch needs to be set to preset/song/set1-5 and the others set to slave.

To select any of the modes press 2nd and then the SET MODE switch.

Using the up “▲” arrow or the down “▼” arrow you can scroll through the operating modes available.

GLOBAL PRESET

The SC1 (with software version 1.32 or higher) features a GLOBAL PRESET which can be accessed from any preset in any mode (Preset, Song or Set).

Pressing the preset button twice will activate the GLOBAL PRESET.

Press the preset button again, and you're back where you came from.

The GLOBAL PRESET is located in Bank 25 Preset 5.

This feature can be bypassed – look for more details on page 27.

8. Preset mode

The basic (factory default) mode of the SC-1 is the PRESETS mode. This is the standard preset/bank mode known from most MIDI foot controllers.

The SC-1 utilizes a total of 125 presets divided into 25 banks containing 5 presets each. Each preset is capable of storing all MIDI program change and controller change data programmed (See section 9 to learn how to set up the MIDI data)

Each bank/preset has it's own 12-character display – divided in two sections – one 2-character display and one 10-character display.

The 2-character display will show the bank number, and the 10-character display will show the unique title of each preset (See section 12).

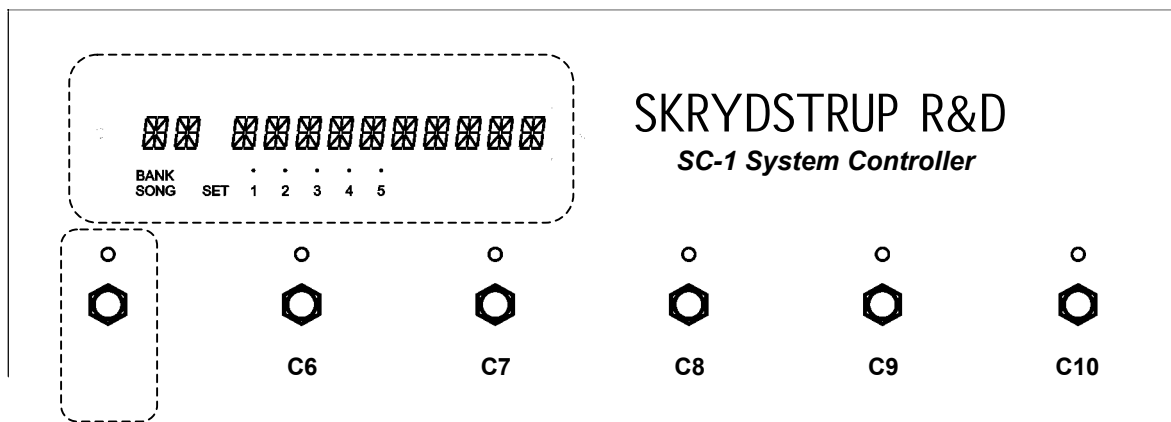

The 5 presets in each bank are selected via the numbered switches 1 through 5.

To increment a bank, press the up “↑” arrow switch.

To decrement a bank, press the down “↓” arrow switch.

Continued depression of either of these switches will result in repetitive accelerating incremented or decremented operations.

As you change banks, the bank will not be selected until a preset number is selected.

In other words, you are able to scroll through the 25 banks, and nothing will be recalled unless one of the numbered switches 1 through 5 is selected.

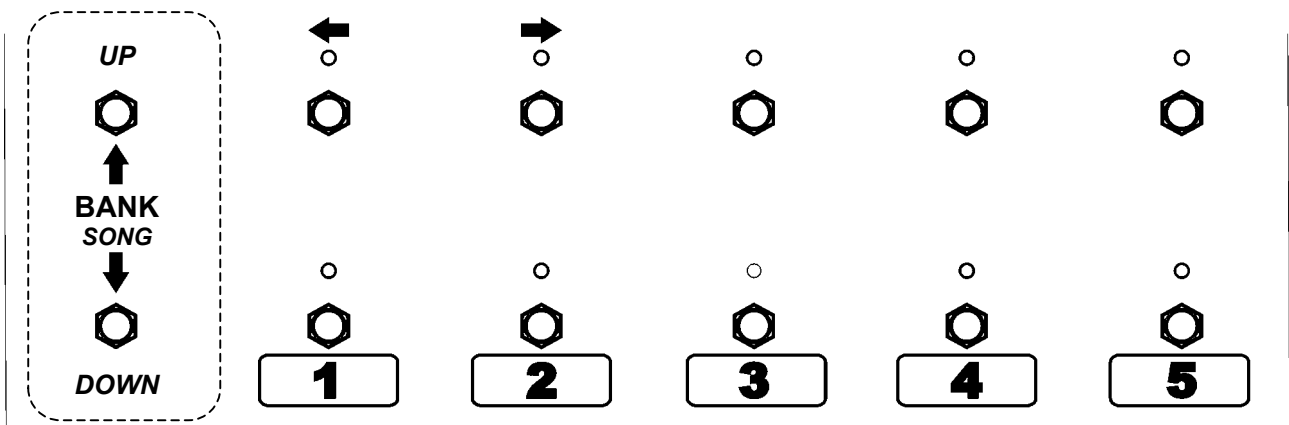

9. Song mode

In SONG mode the particular information stored in each of the 125 presets, can be arranged in any desired order, for access and recall during the performance of SONGS. Each SONG can contain up to 5 presets.

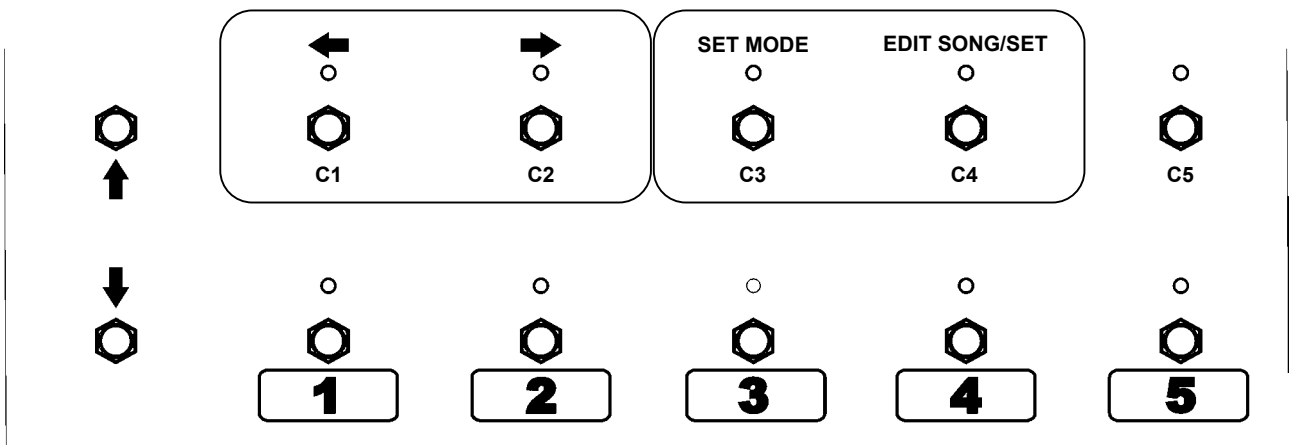

9.1 Accessing the song mode.

To enter the SONG mode, press 2nd then the SET MODE switch.
Using the up “↑” arrow or the down “↓” arrow you can scroll through the available modes.

Select SONGS.
Press 2nd to exit the programming.

The display will now show the song number and the title of the song.

8.2 Modifying a song

You can create up to 99 songs, each with their own unique title.

Select the song number (1-99) you wish to modify.

Now, press 2nd and then the EDIT SONG/SET switch.

The display will now show the preset number (1-5) within the selected song in the 2-character display, and the bank and preset number of the presets actual origin in the 10-character display.

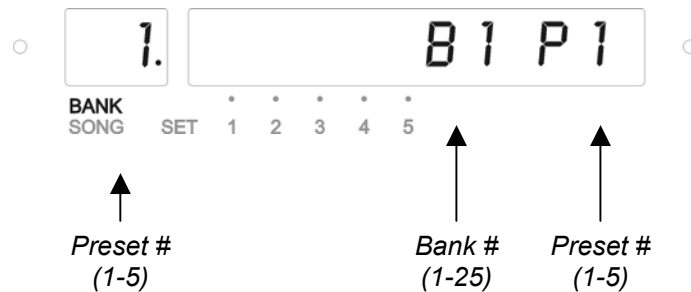

When you have entered the original bank and preset number for preset 1 in this song, press ENTER to store the values modified.

Move on to preset number 2 in this song, by moving the decimal point to the preset number in the 2-character display, and via the up “↑” arrow select preset 2.

Now modify the original bank and preset number as preferred.

Repeat this procedure for preset 3, 4 and 5, if desired.

HINT!

To ensure that it is the correct bank-preset selected, the unique title of the original bank-preset can be displayed by pressing the C5 switch.

10. Set mode

Once you have created the songs you want to use, you are able to organize the songs into 5 different set lists, each containing up to 50 songs.

10.1 Accessing the set mode.

To enter set mode press 2nd then the SET MODE switch.
Using the up “▲” arrow or the down “▼” arrow you can scroll through the available modes. Select i.e. SET 1.

10.2 Editing the set.

Now, press the EDIT SONG/SET switch.
The 2-character display will now show the song number (1-50) within the actual set, and the original song number is shown in the 10-character display.
Using the right “▶” arrow you can move the cursor to the 10-character display, and with the up “▲” arrow or the down “▼” arrow you can scroll through the 99 songs available.

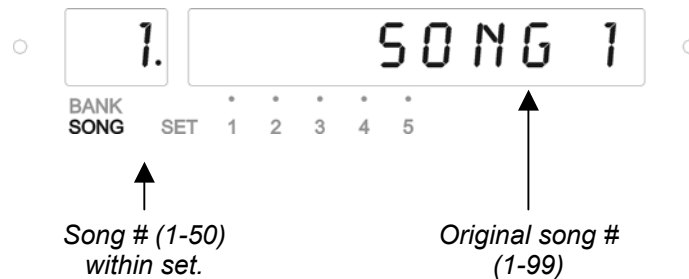

To specify song # 2 in the set list, use the left “◀” arrow to place the cursor in the 2-character display. Use the up “▲” arrow to select song # 2. Use the right “▶” arrow to move the cursor to the 10-character display, and with the up “▲” arrow or the down “▼” arrow, select the original song number or title.

Repeat this procedure until you have created the set list desired.
If you want to organize set list 2-5, press SET MODE switch and choose the set list you want to modify. Repeat the procedure described above.

HINT! While in the EDIT SONG/SET menu press the C5 switch to view the actual title of the song selected.

When you are done, press 2nd to exit.
In the 10-character display a dot will indicate which set is active.

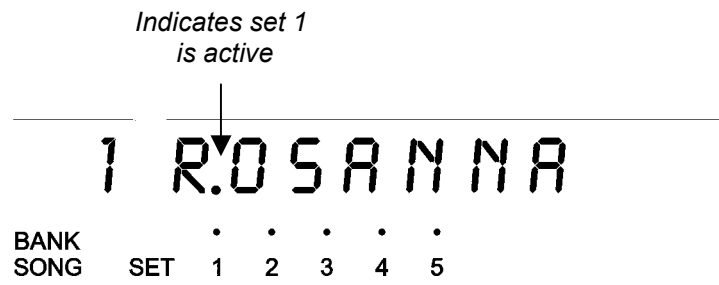

11. MIDI menu

MIDI menu is where all MIDI data is programmed.
The MIDI menu is available only in preset mode.

Options available:

- **PROGRAM CHANGE** Define program change commands.
- **CONTROLLER** Define CC# and MIDI channel for each controller switch.
- **PEDALS** Define CC# and MIDI channel, as well as specific pedal value for each controller port.

Press 2nd then MIDI switch to enter the MIDI menu.

11.1 PROGRAM CHANGE menu

To send MIDI program change messages, enter PROGRAM CHANGE mode.
Program change commands can be defined for every midi channel in every preset.
The 2-character display shows the MIDI channel. You can scroll through all 16 channels by using the up “↑” arrow or the down “↓” arrow.
Use the left “←” arrow or the right “→” arrow to move the cursor between the 2-character display and the sections available in the 10-character display.
The 10-character display shows the program change message you want to send on the selected MIDI channel – displayed in the 2-character display. You can send message 1-128 or OFF.
All values entered are stored in real time.
SC-1 is able to send program change messages and control change information on each of the 16 MIDI channels simultaneously.

In the example shown below Midi channel 1 is set for program change 42.
Use the left “←” arrow to step back to the MIDI menu or 2nd switch to go back to the current preset.



11.2 CONTROLLER menu

This menu is used for modifying the Control Change type and MIDI channels of the C1 – C10 controllers. These settings are global and cannot be different for every preset. In the CONTROLLER menu the 2-character display shows the switch number. I.e. 1 equals C1, 2 equals C2 and so on. In the 10-character display you set the CC number and the MIDI channel. Factory default is MIDI control change (CC) numbers that matches our MR8 Loop System. Factory default is MIDI control change (CC) numbers that matches our MR8 Loop System.

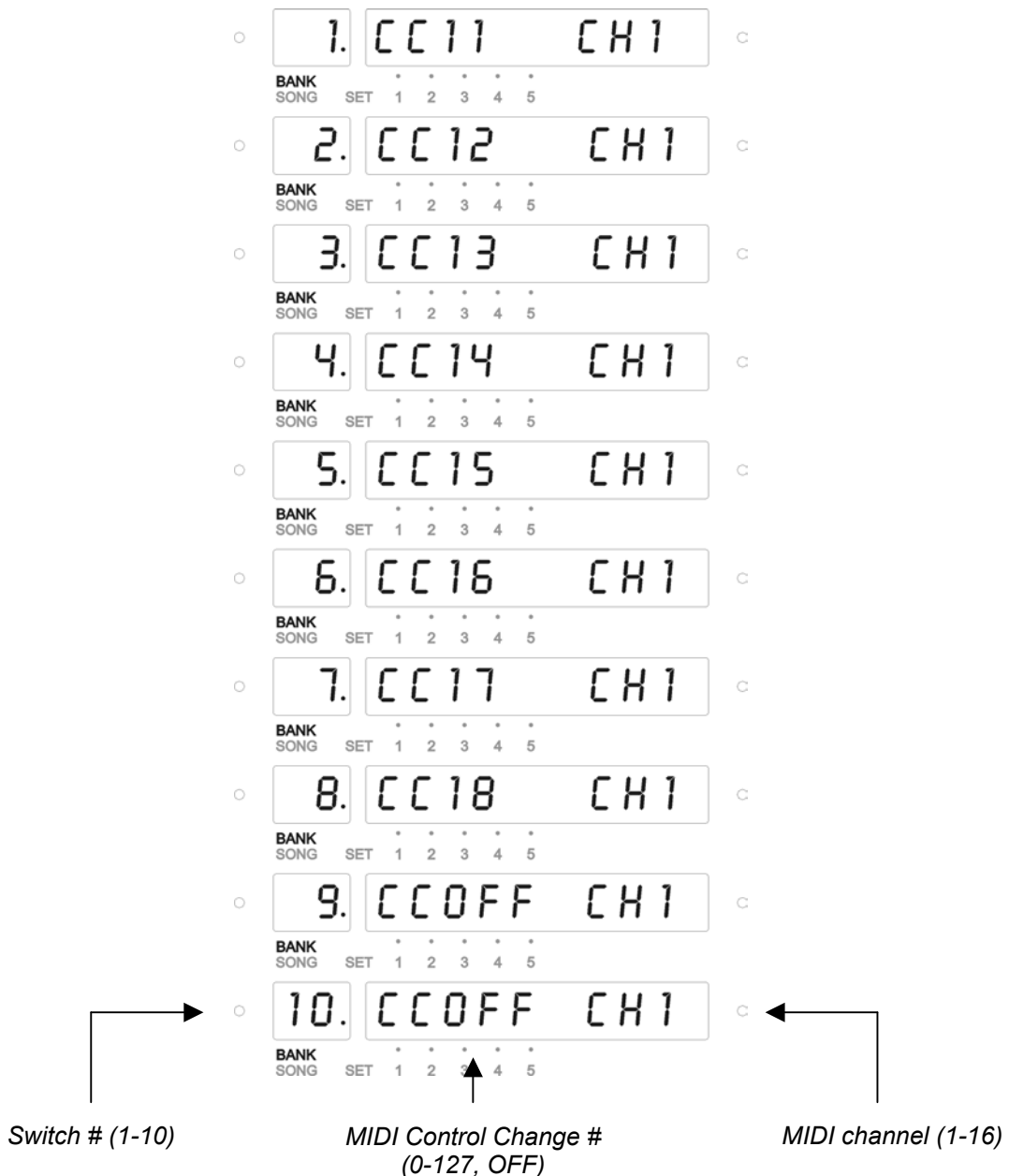

If you are using a different Loop System or unit you want to control via control change, refer to the owner's manual of the device you need to control, for MIDI control change numbers and channel.

11.3 PEDALS menu

Options available:

- **PEDAL CC**
- **PEDAL GLOBALS**
- **PEDAL VALUE**

PEDAL CC

In PEDAL-CC menu your options are OFF, GLOBAL or a specific MIDI CC number and MIDI channel for P1/P2.

If you choose GLOBAL, the settings will be as programmed in the PEDAL GLOBAL menu. If you choose a different MIDI CC number and MIDI channel, the global settings will be ignored.

The editing procedure works exactly like in Controller Mode. The 2-character display now shows the pedal number.



PEDAL GLOBALS

In PEDAL GLOBALS menu you set the global MIDI CC and MIDI channel for P1/P2. These settings are global, but they can be ignored by the settings in the PEDAL-CC menu. The global setting is intended to use for the predominant setting. If you i.e. primarily use P1 for controlling a certain parameter (i.e. master volume) you program the pedal settings needed for this specific operation.

The editing procedure works exactly like in Controller Mode. The 2-character display now shows the pedal number.



In the example shown Pedal 1 is set for control change 7 – midi channel 7. Pedal 2 is set for off.

Again, use the left “←” arrow or the right “→” arrow is to move the cursor between the sections available, and use the up “↑” arrow or the down “↓” arrow to change value in the section selected.

PEDAL VALUE

PEDAL-VALUE is a feature never seen in a MIDI board before. This feature enables you to store specific pedal values in each preset. When using a MIDI controllable VCA, or any multi efx machine (like the TC Electronic G-Force) with a MIDI controllable volume, you will i.e. be able to program specific volume levels or any specific control change value in each preset.

Example:

- You have a MIDI controllable VCA like i.e. the Rocksonics MVCA-4.
- Set the MIDI channel on the VCA for i.e. channel 7. Volume is controlled on CC# 7.
- Press 2nd then MIDI.
- Use the up “↑” arrow or down “↓” arrow to select the PEDALS menu.
- Press ENTER or right “→” arrow.
- Use the up “↑” arrow or down “↓” arrow to select the GLOBALS menu.
- Press ENTER or right “→” arrow.
- Use the up “↑” arrow or down “↓” arrow to alternate between P1 and P2.

- Press the right “➡” arrow.
- Set i.e. pedal 2 for CC7 (control change number 7) and CH7 (MIDI channel 7). The VCA and the SC-1 will now be able to communicate.
- Use the left “⬅” arrow to return to where the display reads GLOBL.
- Use the up “⬆” arrow or down “⬇” arrow to select the VALUE menu.
- Use the up “⬆” arrow or down “⬇” arrow to select pedal 2. The 2-character display should read 2 (pedal 2).
- Now, enter the PEDAL-VAL menu and by using the up arrow or the down arrow
- Use the right “➡” arrow is to move the cursor to the 10-character display. The factory default value is 127 (max.). By using the up “⬆” arrow or down “⬇” arrow, or the expression pedal connected to P2 – you can now alter the value. Settings possible is anywhere between 0 (min.) and 127 (max.). This way you can pre-program any volume levels needed for your performance, in every preset.

12. TITLES menu

After the bank-preset or song has been selected, titles for bank-presets and songs can be entered or modified by pressing 2nd, and then the TITLES switch.

The decimal point is blinking next to the character to be entered or modified.

Move the decimal point by using the left “◀” arrow or right “▶” arrow.

The selected character can be altered using the up “▲” arrow or down “▼” arrow.

HINT!

If you want to delete the entire title, simply press the C5 switch.

13. COPY menu

The copy menu allows you to copy ...

- ***a bank-preset into another bank-preset.***
- ***a song into another song.***

This menu is available only in preset and song modes.

13.1 To copy a bank-preset into another bank-preset:

1. Select the bank-preset you wish to copy.
2. Press 2nd, and then COPY.
3. The cursor is blinking next to the bank number. By using the up “↑” arrow or down “↓” arrow select the desired bank (1-25) number you wish to copy into.
4. By using the right “→” arrow the cursor will move to the preset number. By using the up “↑” arrow or down “↓” arrow select the desired preset number (1-5) you wish to copy into.
5. Press ENTER to store the copy.
6. Press 2nd to exit programming.

13.2 To copy a song into another song:

1. Select the song you wish to copy.
2. Press 2nd, and then COPY.
3. The cursor is blinking next to the song number. By using the up “↑” arrow or down “↓” arrow select the desired song (1-99) number you wish to copy into.
4. Press ENTER to store the copy.
5. Press 2nd to exit programming.

14. System menu

The SYSTEM menu is used for MIDI Bulk functions, general information on software; restore functions as well as calibration of expression pedals.

Options available:

- **MIDI BULK** Bulk Dump, Bulk Load and Device ID.
- **VERSION** Indication of software version.
- **RESTORE** Restore to factory default.
- **PEDALS** Calibrate your expression pedals, select Grab function and select type of pedal connected to P1/P2.
- **GLOBAL PR** Determines if the Global Preset should be ON or OFF.

14.1 MIDI BULK

DUMP

Enables you to dump data stored in the SC-1 as sysEx data, to i.e. your computer. This menu contains the following options:

- **DUMP ALL** Dump all data. Press ENTER to instantly start dumping all data.
- **DUMP PSET** Dump one or all presets. Press ENTER and select all or bank and preset number by using the arrows. Start dumping by pressing ENTER.
- **DUMP SONG** Dump one or all songs. Like DUMP PSET.
- **DUMP SET** Dump one or all sets. Like PUMP PSET.
- **DUMP GLOB** Dump global data (controller and pedal settings). Press ENTER to dump global data.

Use the left “◀” arrow to step back to the previous menu.

LOAD

Enables you to load any sysEx data previously dumped. The sysEx data can be sent to the SC-1 at any time, but it is recommended that you use this function for that purpose.

14.2 VERSION

Displays the software version on your SC-1. Software updates can be downloaded on <http://www.skrydstrup.com>

WARNING!
This procedure will permanently erase all user settings!

14.3 RESTORE

Restore to factory default. ALL, PRESET, SONG, SET or GLOBALS can be selected.

- ALL** – means that all settings in the SC-1 will be restored to factory default.
- PRESET** – means that all presets will be restored to factory default.
- SONG** – means that all songs will be restored to factory default.
- SET** – means that all sets will be restored to factory default.
- GLOBALS** – means that all global data will be restored to factory default.

- Press 2nd then SYSTEM.
- Use the up “↑” arrow or down “↓” arrow to select RESTORE menu.
- Press ENTER or right “→” arrow.
- Use the up “↑” arrow or down “↓” arrow to select the type of restore required.
- Press ENTER to confirm the restore procedure.

14.4 PEDALS

CALIB PDLS (abbreviation for Calibrating Pedals)

Enables you to specify the minimum and maximum point of your expression pedals to the SC-1. This ensures best possible performance.

- Press 2nd then SYSTEM.
Use the up “↑” arrow or down “↓” arrow to select CALIB PDLS menu.
- Press ENTER or right “→” arrow.
- Use the up “↑” arrow or down “↓” arrow to alternate between P1 and P2.
- Press ENTER or right “→” arrow.
The 10-character display now reads MINIMUM.
- Place the pedal at its minimum point, and press ENTER.
The 10-character display now reads MAXIMUM.
- Place the pedal at its maximum point, and press ENTER.

You have now calibrated your pedal. Repeat procedure for the second pedal if necessary.

PEDL SCALE (abbreviation for Pedal Scale)

Enables you to specify the type of pedal used in P1/P2.
Possible values are...

- PDL LIN (Pedal Linear) for linear taper of the expression pedal.
- PDL LOG (Pedal logarithmic) for audio/logarithmic taper.
- PDL MOM (Pedal Momentary) for momentary footswitch.
- PDL LATCH (Pedal Latching) for latching footswitch.

Selecting the logarithmic taper will try to make a audio/logarithmic taper act like a linear one.
When using a momentary or latching switch for control change functions, PDL MOM (Pedal Momentary) should be selected.

The factory setting for these parameters is PDL LIN (Pedal Linear).

- Press 2nd then SYSTEM.
- Use the up “↑” or down “↓” arrow to select PEDL SCALE menu.
- Press Enter or right “→” arrow.
- Use the up “↑” or down “↓” arrow to alternate between P1 and P2.
- Press Enter or right “→” arrow.
- Use the up “↑” or down “↓” arrow to select the scale required.
- You do not need to press ENTER to store the settings.

14.5 GLOBAL PRESET

GLOBAL PR (abbreviation for Global Preset)

Enables you to specify if the Global Preset feature should be ON or OFF.
Use the up “↑” or down “↓” arrow to select the status.

15. Cables

If you want to use the ports P1/P2 on the SC-1, it is important to use proper cables.

P1/P2 uses a standard 1/4" TRS stereo jack, and is configured as follows:

TIP is pedal input
RING is pedal output
SLEEVE is ground.

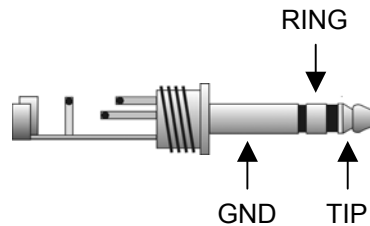

The ring of this jack is internally wired to +5V through a 200 Ohm resistor, so that external short circuits will not damage the unit.

15.1 USING AN EXTERNAL EXPRESSION PEDAL

A standard 1/4" TRS stereo jack cable provides connection for an external expression pedal, like the Boss FV300L pedal.

15.2 USING AN EXTERNAL VOLUME PEDAL

A 1/4" TRS stereo jack cable into 2 x 1/4" mono jack cable provides connection for an external volume pedal, like the Ernie Ball 6166 volume pedal.

The cable should be configured as the drawing shown below.

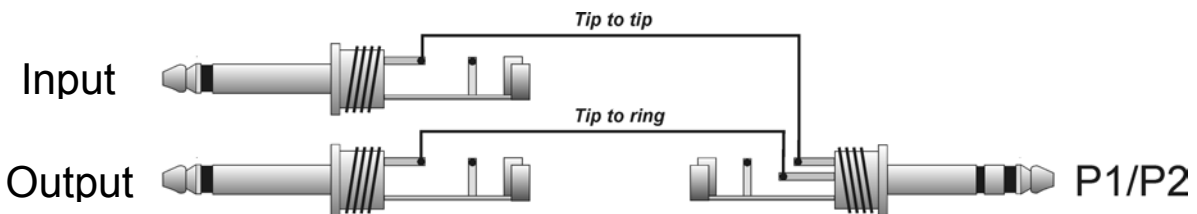

15.3 USING AN EXTERNAL SWITCH

A standard 1/4" mono jack cable provides connection for an external momentary switch, like the Boss FS-5U.

16. MIDI Implementation Chart

Model: SC-1 System Controller

Version: 1.2

Date: May 2002.

Function		Transmitted	Recognized	Remarks
Basic Channel	Default	1-16	1-16	
	Changed	1-16		
Mode	Default	X	X	
	Messages	X	X	
	Altered	X	X	
Note Number	True Voice	X	X	
Velocity	Note On	X	X	
	Note Off	X	X	
After Touch	Key's	X	X	
	Channel	X	X	
Pitch Bend		X	X	
Control Change	0-127, off	O	X	
Program Change	True Number	O	X	Programs 1-128
System Exclusive		O	O	
System Common	Song Position	X	X	
	Song Select	X	X	
	Tune Request	X	X	
System Real-Time	Clock	X	X	
	Commands	X	X	
Aux. Messages	Local On/Off	X	X	
	All Notes Off	X	X	
	Active Sensing	X	X	
	System Reset	X	X	

X: NO O: YES